



Banner Catalog

UNIVERSAL CONCEPTS
www.christmasdecorandmore.com
800.522.0718
sales@universalconceptsus.com

Table of Contents

Vinyl Banners vs. Fabric Banners	3
Making your Banners Count	4
Banners, Spring / Summer	5-6
Banners, Fall /Winter /Holiday.....	7-9
Custom Banners	10
Bannerware Choices	11
Banner Hardware and Construction	12
Banner Design Choices	13
Pricing and Warranty Information	14-15

About us

Universal Concepts is a commercial decorating and lighting company based in Cumming, Georgia. We have been designing, creating, and installing all types of exciting commercial decoration for more than 40 years. We have the experience and customer service to help you make new banners an easy choice for your city, park or town!



Vinyl Banners vs. Fabric Banners

VINYL BANNERS

All of our banners are constructed of the highest quality outdoor-rated materials, printed, sewn and built to withstand the elements for years to come! See more details and photos about our banner construction on page 12.

Our digitally printed vinyl banners are constructed of heavy and durable 18 ounce outdoor vinyl which is printed with up-to-date digital printers and high quality inks. They receive our standard UV protective coating which protects them from harsh sun and weather exposure. Since they are digital prints, you have maximum flexibility in your choice of design elements and colors. Any colors, photos, text and logos can be part of a digital print banner.

Look at some of our past designs on the following pages to jump-start your creative process - and let us help you with design services available to incorporate your photo, logo, message and background (additional design fees apply in this situation).



FABRIC BANNERS

Our Digital MainStreet Fabric banners are constructed of heavy 100% marine acrylic fabric and give you the same design flexibility of digital printing with the more traditional rich look of a heavy duty fabric. Our Digital MainStreet Fabric banners use the best quality inks with premium fabric designed to enable vibrant and accurate color printing (See more details about this process on page 12.)

Classic **Screen Printed** banners on 100% marine acrylic are also available for custom orders and have their own unique look.

A screen printed banner will look bolder, crisper and simpler than a digital print and can often offer more "pop" and contrast when viewed from a distance.

Look over the next few pages of banners from previous customers to see inspiration for your project!



Make your Banners Count!



For any season, event, school, local attraction, festival or holiday, banners can help you make the most of space you already have. Think banner pairs for double impact, and remember that Universal Concepts is an industry leader for garland sprays and wreaths or lighted pole decor which will give your banners that extra visual boost.

Historic



Sample Digital Designs - Spring and Summer

If you're not sure where to start and want to use a design that's tried and true, look below for a sampling of some of our banner designs. If you wish to use or adapt some of these designs (some have space for an imprint or custom text) - extra fees may apply.



U16d829



U17d839



U19d853



U41175



U2111192



U4545044



U9508494



U8415077



U6690731

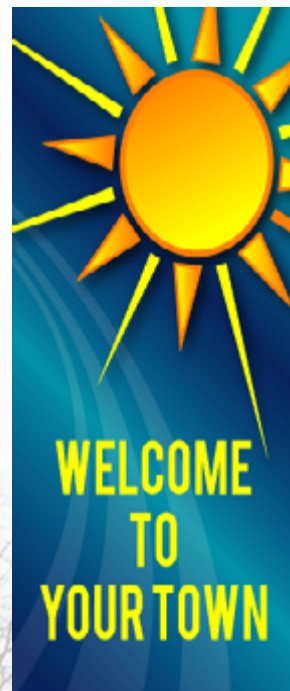

U17d837

Sample Digital Designs - Summer and Patriotic

Below are some of our most popular banners from past work. If you wish to use or adapt some of these designs for patriotic and summer-themed digital banners, some have space for an imprint (custom text). Extra fees may apply for customization.



U17d838



U17d840



U17d846



U17d841



U7509429



U2241697



U3919917



U6604536



U299939



U7114189

Sample Digital Designs - Fall and Winter

Below find our newest fall and winter-themed digital banners. Some have space for an imprint (custom text) - extra fees apply.



U19d849



U2766204



U5464491



U6218137



U9326860



U16d836d



U17d844



U19d852



U931113



U8393988

Sample Digital Designs - Holidays

Some of our fresh new and bright holiday designs in digital banners are below. Some have space for an imprint (custom text) - extra fees apply.



U17D842



U17D843a



U17D843b



U17D843c



U17D845

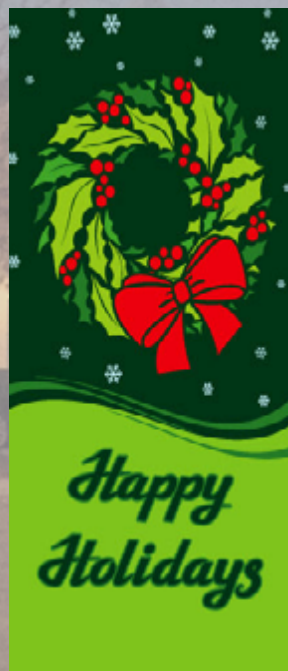

U19D847

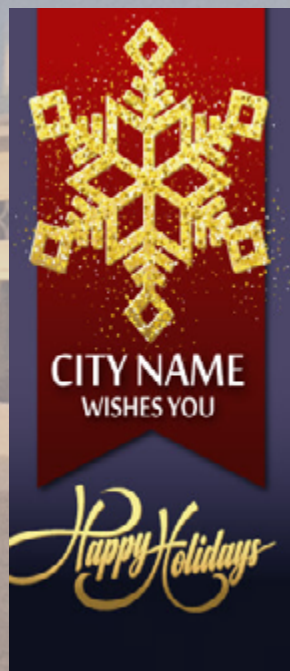

U19D848



U19D854

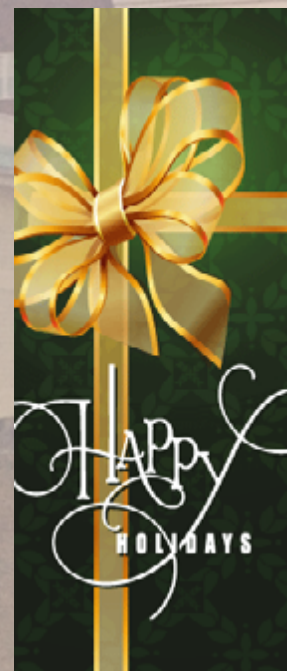

U3691



U470545

Sample Digital Designs - Holidays

Below see more of our holiday-themed designs in digital banners. Some have space for an imprint (custom text) - extra fees apply.



U1791932



U2430160



U2444204



U4599790



U5590846



U6041717



U6797651



U8159948



U9749356



U9917861

Custom Design Examples (Digital and Screen Print)

On this page you can see examples of some of the custom designs for past clients, both in screen-printed format and in digital vinyl or fabric print.



The examples above showcase some of the digital custom designs that are possible when you send us your ideas, logos, photos and color schemes. You can have new designs for every event and season!



Above see some of the bold custom screen print designs that are possible when you choose durable sunbrella fabric and a palette of one to four ink colors.

Bannerware Choices

Single Base Systems: Fibreflex I and II



Fibreflex I

Ideal for 30" x 60" and smaller banners installed on metal or concrete poles. Not recommended on wooden poles for banners larger than 30" x 60".

\$86 per set*

The Single Fibreflex I Bracket Set includes:

- (2) 2" x 6" aluminum bases
- (2) 13/16" removeable cantilevered rod arms
- "D" clips to hold rod arm to base
- 3/4" x 10' stainless steel banding straps with buckles
(banding tool required for installation) - see hardware page

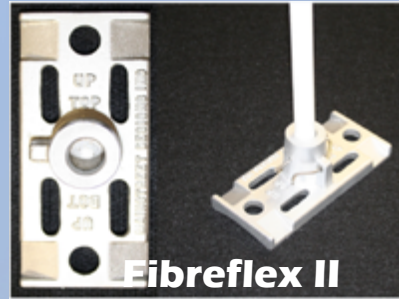

Fibreflex II

For banners 30" x 60" and larger, this system may be mounted to either metal or wooden poles. The wide base is especially adaptable to wooden poles where either strapping or bolts can secure the base to the pole.

Note: wooden poles require more strapping.

\$100 per set*

The Single Fibreflex II Bracket Set includes:

- (2) 3" x 7" aluminum bases
- (2) 13/16" removeable cantilevered rod arms
- "D" clips to hold rod arm to base
- cable ties to hold banner to base
- 3/4" x 10' stainless steel banding straps with buckles
(banding tool required for installation)- see hardware page

***add \$15 per set for a black powder-coated finish. Black finish on banner arms are only available on Fibreflex LL system.**

Adjustable Double Base System: Fibreflex III

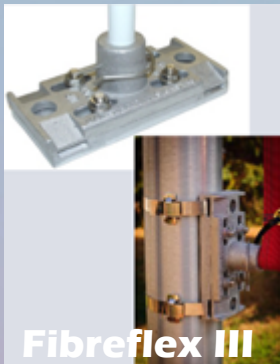

Fibreflex III

When displaying banners 30" x 60" or larger in area of strong persistent winds, the Fibreflex III bracketing system is highly recommended. This system has an overall adjustment allowance of 3 inches, allowing easy changeovers and taut banner installation.

\$130 per set*

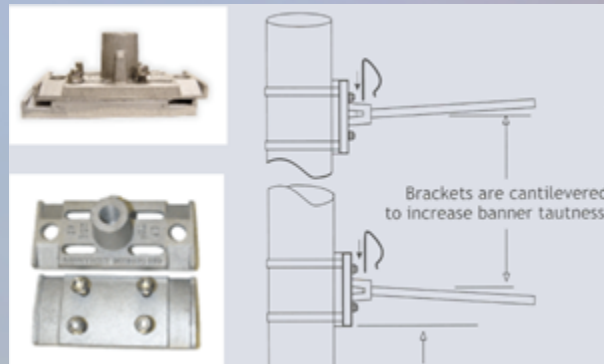

Brackets are cantilevered to increase banner tautness

The Fibreflex III bracketing system has consistently proven to be superior in performance, reliability and value in the most wind-prone areas across the country.

***add \$22 per set for a black powder-coated finish. Black finish on banner arms are only available on Fibreflex LL system.**

Bracket for Low Level Poles: Fibreflex LL

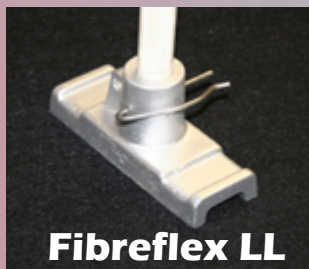

Fibreflex LL

Designed specifically for use on low level decorative lamp posts using 18" x 45" and smaller banners. The back of the aluminum base is channel shaped to fit into grooves of fluted lamp posts.

\$60 per set*

The Fibreflex LL Bracket Set includes:

- (2) 1 3/4" x 5" aluminum bases
- (2) 3/4" removeable fiberglass rod arms
- "D" clips to hold rod arm to base
- Cable ties to hold banner to base
- (4) ideal bands

***add \$15 per set for a black powder-coated finish. Black finish on banner arms are only available on Fibreflex LL system.**

Hardware / Banner Construction

Miscellaneous Hardware:

order extra parts:

13/16" Fiberglass rod arm.....	\$ 14.00 each
3/4" Fiberglass rod arm.....	\$ 13.00 each
Fibreflex II/III Top Base.....	\$32.00 each
Fibreflex III Bottom Base.....	\$30.00 each
Fibreflex I Base	\$21.00 each
Fibreflex LL Base.....	\$ 18.00 each
Heavy Duty Cable Ties (bag of 100).....	\$35.00 each
D-Clip	\$ 1.25 each
Stainless steel buckles (box of 100).....	\$120.00 each
Stainless steel buckles (box of 100-black)	call
100' roll of 3/4"	
stainless steel strapping	\$140.00 each
100' roll of 3/4" black strapping.....	call
39" Ideal Bands (silver finish)	\$5.00 each
Banding Tool (pictured below).....	\$165.00 each



Fabric Banner Construction:

Every banner we make comes with our unique double-lined rod pocket and double-folded side hems. Solid brass grommets are placed in all four corners for added strength.

Digital MainStreet Fabric banners are printed on our exceptionally smooth and durable MainStreet fabric which is designed for high resolution printing with maximum color fidelity; we use exceptional quality inks and a UV/Scratch Resistant coating, (something none of our competitors offer). This new fabric printing process is done using materials made in the USA using environmentally conscious processes. These banners are ideal in any sunny, cold or windy setting and carry a warranty of (3) THREE FULL YEARS. Banners must be installed according to instructions on FibreFlex bracketing system and/or approved bracketing system.

You can imprint or personalize any design where space allows.



Vinyl Banner Construction:

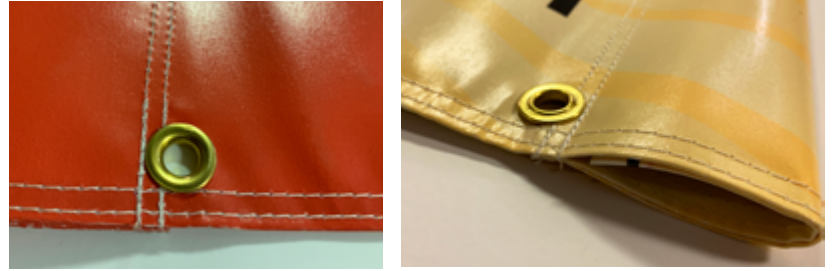

Every digital print vinyl banner comes with our unique double-lined rod pocket. Solid brass grommets are placed in all four corners for added durability.

Our designs are printed on 18 oz. reinforced blackout vinyl and carry a warranty of (3) THREE FULL YEARS. Banners must be installed according to instructions on FibreFlex bracketing system and/or approved bracketing system for the warranty to apply.

You can also imprint or personalize some of our stock banners where space allows.

We take the EXTRA STEP of applying UV Clear Coating to all of our digital banners which makes them last longer and keeps up the new and fresh appearance. This added value is vital to offering the absolute best product possible. UV Clear Coating is the process of screen-printing a clear, scratch resistant, UV resistant coating over the digitally printed banner. This process gives the banner extra life and renders them virtually impervious to fading. Please call or email for a sample of a UV Clear Coated banner and ask our competitors to quote this added process.

Classic Screen-Printed banners on our marine acrylic fabric

are also available for special orders in larger quantities. These banners use specially formulated and highly durable thermal inks fused one at a time onto heavy-duty marine acrylic. The manufacture of these screen printed banners uses a proprietary high temperature process, and they remain pliable and colorfast through the lifetime of the banner. The combination of fused thermal inks and 100% acrylic fabric give exceptional serviceability and value to our banners.

To find out more about custom orders of screen-printed inks on our classic marine acrylic fabric, give us a call at (800) 522-0718

Design Choices for your Digital Print Banners

Digitally printed banners present many choices to our customers! We can help with the design of your vinyl digitally printed banners. Just send us your logos or other images, being sure that the file resolution is high (ideally 300 dpi). We can send you mockups of your banner designs for your edits and approval (Some design fees will apply). Stock banner choices listed in the catalog with no personalization are the standard pricing on page 14.

Sample DIGITAL PRINT TEMPLATE:

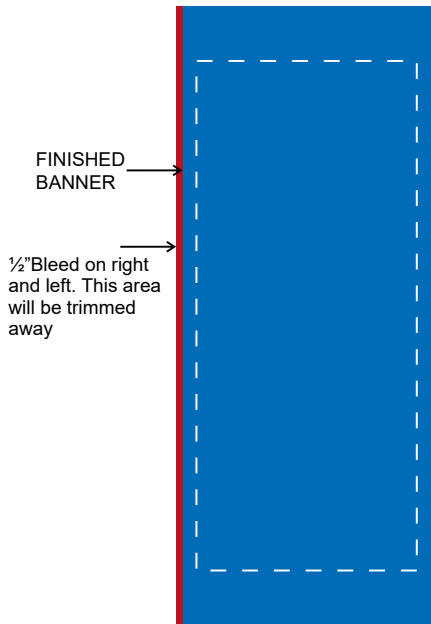

CONSIDER YOUR SHAPE:

The shapes of our most common banner sizes are represented at right; keep in mind the final shape of your banner when you are considering text and images that will be on display: some of the shapes are longer and thinner, and some are wider

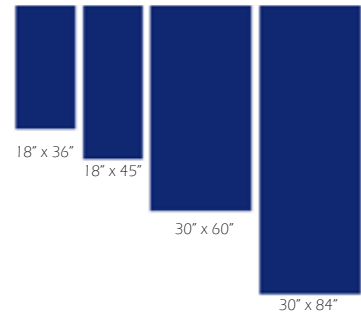

DESIGN FREEDOM:

The design flexibility of digitally printed banners are their strong point. **Any image and any colors may be used**, so the sky is the limit when you are in your planning stages. Send us a sketch of your ideas and we can incorporate your logo, tagline, and images into a beautiful design which is visible from a distance.

Guidelines for Images, Colors and Text:

Raster Images:

Raster Images should have a **minimum of 150 dpi** (dots per inch) **at final output size** or a proportional size.

Text:

All text has to be **converted to outlines or curves** to avoid font issues.

KEEP ALL TEXT 4" FROM THE TOP AND 4" FROM THE BOTTOM TO ALLOW FOR POCKETS AND SEWING. GRAPHICS AND IMAGES ARE OK TO GO INTO THE POCKETS, JUST NO TEXT.

Spot Colors:

All spot colors will be printed as CMYK.

Bleed Example:

A 18" x 45" banner will have a layout dimension of 19" x 45". The additional inch is provided for the bleed area, left and right. The banner will be printed and then cut down to 18" x 45" so that graphic bleeds off the edge of the material.

File Preparation:

Files can be saved as an **.eps, .ai, .pdf**
Be sure to be work in CMYK and include bleeds.

LET US HELP
YOU GET
GREAT
BANNERS
TODAY!

Call
(800) 522-0718

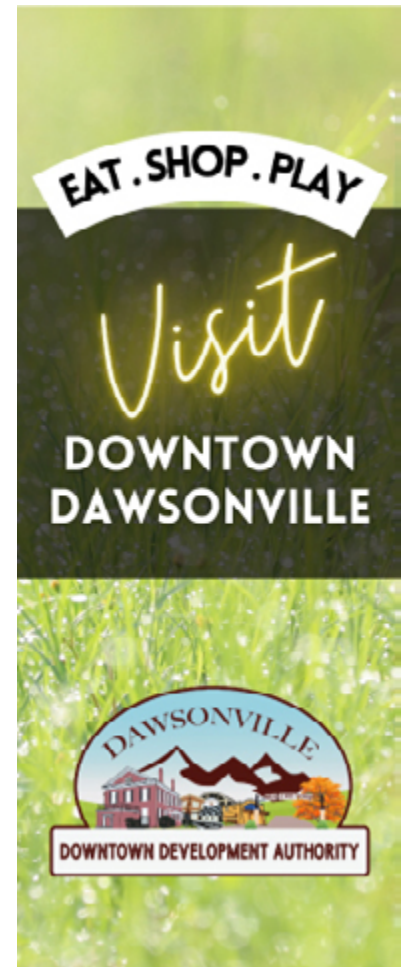

Digital Print Banners PRICING:

Digital Vinyl Banner Pricing Guidelines:

18" x 36"	\$55
18" x 45"	\$60
30" x 60"	\$100
30" x 84"	\$115

Personalized changes (imprints) may be made to sample designs shown in this catalog. For the same imprint on all banners, a \$10 per banner charge applies. Also, custom design services for original digitally printed designs are available. Call for details.

Digital MainStreet Fabric Banners: Call for Pricing

Screen Print Banners PRICING:

Screen Print Banner Pricing Guidelines:

colors:	18" x36"	18" x 45"	30" x 60"	30" x 84"
1 ink	\$67	\$70	\$89	\$96
2 inks	\$73	\$76	\$99	\$108
3 inks	\$78	\$80	\$106	\$121

Personalized changes may be made to stock screen print designs; A \$75 setup fee plus \$10 per banner up-charge will apply for personalized imprints (\$10 imprint charge is for the same imprint on all banners - an individual 1 color imprint is \$40). Pricing above assumes a 10-banner minimum order. Also, custom design services for original screen printed designs are available. Call for details.

WARRANTY INFORMATION

Digital Print Banner Warranty:

Stock and custom digital print banner designs carry a warranty of (3) three full years. Banners must be installed according to instructions on FibreFlex bracketing systems and/or approved bracketing systems.

Screen Printed Banner Warranty:

Stock and custom screen print banner designs are printed on 100% marine acrylic fabric and carry a warranty of (3) three full years. Banners must be installed according to instructions on FibreFlex bracketing systems and/or approved bracketing systems.

FibreFlex Bannerware Warranty:

FibreFlex bannerware is warranted for (8) eight full years. Warranty covers defects in materials and workmanship.

About our UV Clear Coating Process for Vinyl Banners:

Our digitally printed vinyl banners are all treated with a clear coating which makes them last longer and look sharp. This added protection is vital to offering the best product possible. This involves a process of screen-printing a clear, scratch-resistant, UV-resistant coating over the digitally printed banner which imparts extra life and renders the product resistant to fading. Call for a sample and ask our competitors to quote this added process.





UNIVERSAL CONCEPTS

christmasdecorandmore.com

800.522.0718

sales@universalconceptsus.com